



# PRINT APPLY P183 VALUE



## INDUSTRIAL STRENGTH

- ❖ Stainless steel fasteners and aluminium cast structure
- ❖ Operating 24/7

## DESIGN AND STATE-OF-THE-ART TECHNOLOGY

- ❖ Metallic black colour epoxy powder paintwork, scratch and corrosion proof
- ❖ Label reel housing fitted with a special inflexible fibreglass polymer disk
- ❖ 3 solenoid valves with a capacity of 800 litres/minute each

## VERSATILITY

- ❖ Available in RH or LH version
- ❖ VALUE can apply labels on top, bottom, in front, on the back, on the side and around the corner of the product with a wide range of pneumatic applicators ( including specific FOR PALLETS )
- ❖ Labels reel housing available up to Ø 280 mm
- ❖ Application of last label printed in "real time" printing,

## SAFETY

- ❖ Sharp edges; encased or button head screws reel housing and liner rewinder disks designed without holes for maximum safety.

**CE marking (in conformity with 98/37/CE standard)**

## MAIN CHARACTERISTICS :

- ❖ Label reel housing diameter : External reel max 280mm, core 45 or 75mm
- ❖ Max Paper Width : 183mm (\*)
- ❖ Usable label dimension: Min & Max. (\*)
- ❖ Usable Printing Area : Min. & Max. (\*)
- ❖ Minimum gap between labels: (\*)
- ❖ Max dispensing speed : (\*)
- ❖ Power Supply : 230V - 50 Hz or 110V and 60 Hz

(\*) it depends on the specific digital print module and application plate installed on the system.

The machine frame includes:

- ❖ a control panel, located on the machine frame, with four alarm or machine status LEDs and four function keys for managing standbys, alarm resets and single label manual applications.

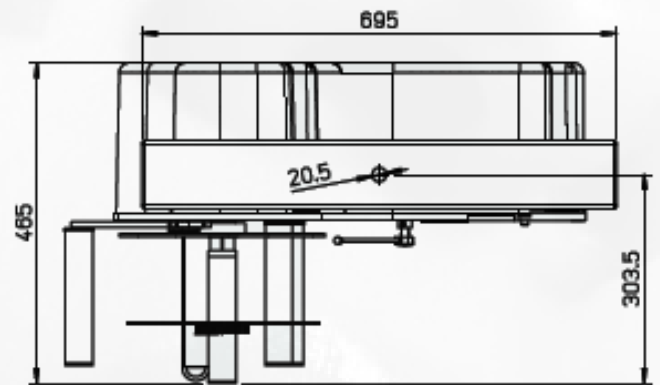
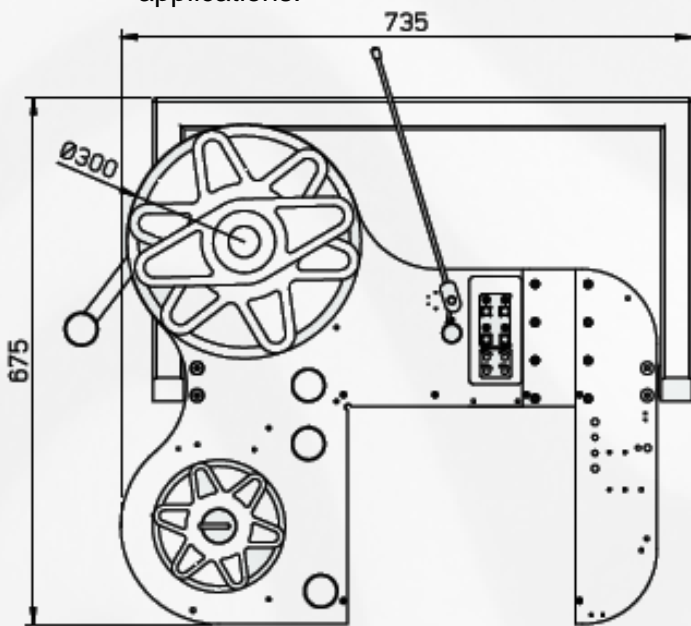

### Available with Various Supports, Adjustments, Applicators....

